

Name **Jesse Robbers**

Date **8/22/10**

Track Temp

Track **Leisure Hours (2010 ROAR Nats)**

Track Condition  Indoor  Tight  Smooth  Hard Packed  Blue Groove  Wet  Low Bite  High Bite  
 Outdoor  Open  Rough  Loose/Loamy  Dry  Dusty  Med Bite  Other

## Front

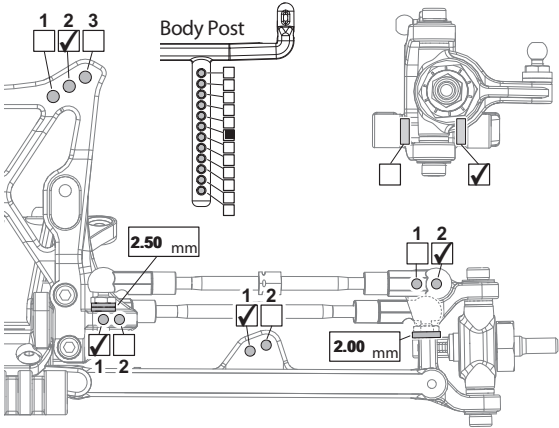

Ride Height  
Bodenfreiheit  
Garde au sol  
車高 **32 mm**

Camber  
AngleSturz  
Angle de carrossage  
キャンバー角 **-1.0 °**

Toe Angle  
Vorspur  
Angle de pincement  
トー角 **1/2 in °**

Steering Block  
Lenkhebel  Trailing  
Ensemble bloc  Inline  
ステアリングブロック

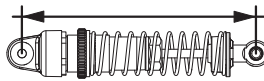

## Shocks

	Front	Rear
Piston Kolbenplatte Piston ピストン	Other	Other
Oil wt. Ölviskosität Grade huile オイル番号	450 HB	500 HB
Bladder Daempfermembran Coupelle ブラダー	stock	stock
Spring Feder Ressor スプリング	Other	Other
Shock Length Dämpferlänge Longueur amortisseur ショック長	83 mm	99.5 mm

## Rear

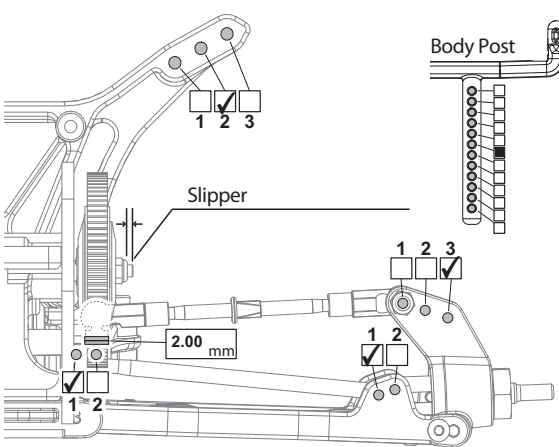

Ride Height  
Bodenfreiheit  
Garde au sol  
車高 **30 mm**

Camber  
AngleSturz  
Angle de carrossage  
キャンバー角 **0.0 °**

Toe Angle  
Vorspur  
Angle de pincement  
トー角    **2/3/4 °**

Kick Up  
Rebond    
Kick Up  
キックアップ **+1/+2**

## Tires

	Front	Rear
Brand Hersteller Marque 使用タイヤ	HB Megabite	HB Beams
Compound Mischung Gomme コンパウンド	Pink	Pink
Insert Einlagen Insert インサート	HPI #103334	HPI #103334
Wheel Felge Jante ホイール	JConcepts	JConcepts
Notes Notizen Notes メモ	Trim inner & outer edges of inserts	Trim inner & outer edges of inserts

## Chassis

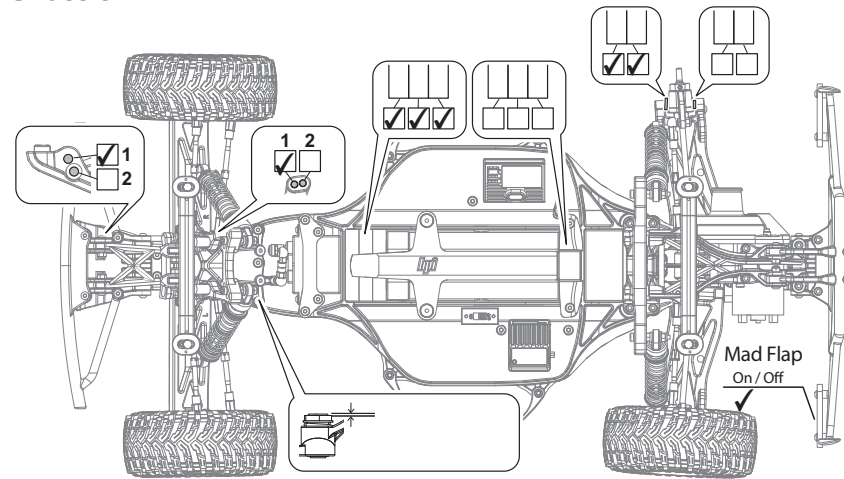

Speedo mounted behind battery under shock tower, 3oz weight in same box speedo is mounted within, HB #3 pistons in rear, HB #1 pistons in front shocks, AE gold front springs, AE silver rear springs, HPI aluminum steering rack, HPI #104867 front pivot block, spindles up.

Note

## Diff

Brand Hersteller Marque ブランド		Oil wt. Ölviskosität Grade huile オイル番号
Notes Notizen Notes メモ	Ball Diff	

## Motor

Motor Motor Moteur モーター	Novak Ballistic 8.5	Spur gear Hauptzahnrad Couronne スパーギア <input type="checkbox"/> <input checked="" type="checkbox"/> <input type="checkbox"/> 77 / 83 / 88 103371 103372 103373
Battery Akku Batterie バッテリー	SMC 4500mah	Pinion gear Ritzel Pignon ピニオンギア
Body Karosserie Carrosserie ボディ	HPI Blitz	ESC ESC ESC ESC Novak Havoc Pro SC
Notes Notizen Notes メモ		