

Setup Sheet Fiche de réglage Setup Blatt セットアップシート



Name Nom **TY TESSMANN**

Date Datum **JULY '09**

Event Veranstaltung **Événement**

2009 FUEL NATIONALS

Track Strecke **Piste**

LEISURE HOURS

Temperature Temperatur **Température**
Air Track

Track Condition Streckenzustand **Conditions de piste**
路面状況

Indoor Outdoor Tight Open Smooth Rough Hard Packed Loose/Loamy Blue Groove Wet Low Bite High Bite Dusty Med Bite Other

Front

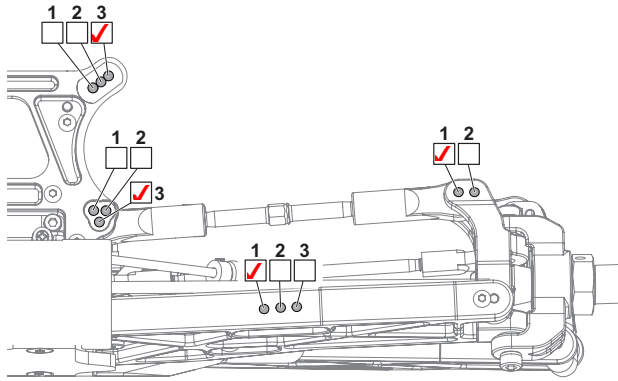

Ride Height Bodenfreiheit **37** mm
Garde au sol 車高

Camber Angle Sturz **-1** °
Angle de carrossage キャンバー角

Toe Angle Vorspur **1 OUT** °
Angle de pincement トー角

Sway Bar Stabilisator **2.3** mm
Barre antiroulis スタビライザー

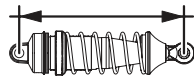

Shocks

	Front	Rear
Piston Kolbenplatte Piston	1.2	1.2
Oil wt. Ölviskosität Grade huile	450	400
Bladder Dämpfermembran Coupelle	STOCK	STOCK
Spring Feder	WHITE	ORANGE
Shock Length Dämpferlänge	102 mm	115 mm

Rear

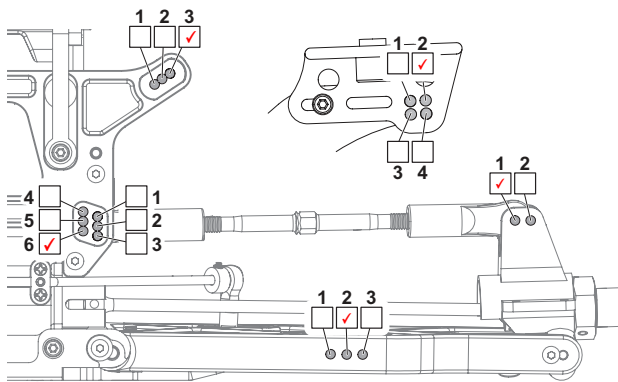

Ride Height Bodenfreiheit **39** mm
Garde au sol 車高

Camber Angle Sturz **2** °
Angle de carrossage キャンバー角

Toe Angle Vorspur **STOCK** °
Angle de pincement トー角

Sway Bar Stabilisator **2.5** mm
Barre antiroulis スタビライザー

Tires

	Front	Rear
Brand Hersteller	AKA NARROW GRID IRON	AKA NARROW GRID IRON
Compound Mischung Gomme	BLUE	BLUE
Insert Einlagen Insert	AKA	AKA
Wheel Felge	AKA	AKA
Notes Notizen	メモ	

Chassis

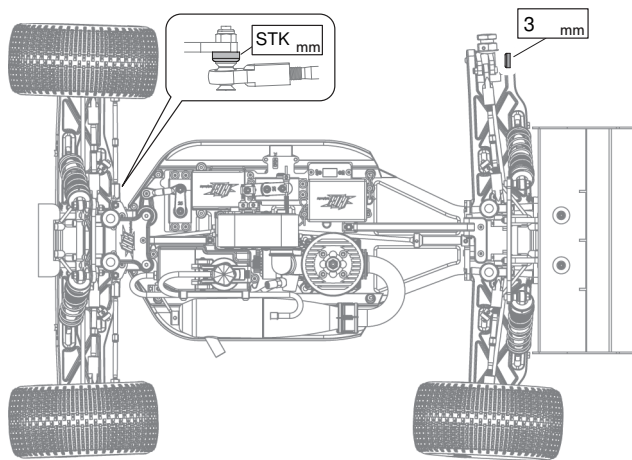

Notes Notizen **THE SWAY BARS ARE KYOSHO PART #IF460-2.5 & IF460-2.3**
メモ

Diff

	Front	Center	Rear
Brand Hersteller	HB	LOSI	HB
Oil wt. Ölviskosität Grade huile	7000	15000	3000

Motor

Engine Motor	OS	Spur gear Hauptzahnrad	50T
Glow Plug Glühkerze	OS	Pinion gear Ritzel	13T
Glow Fuel Modell-Kraftstoff	ODONNELL	Clutch Kupplung	STOCK TRIMMED
Exhaust Pipe Resonanz-Rohr	OS	Notes Notizen	メモ

