

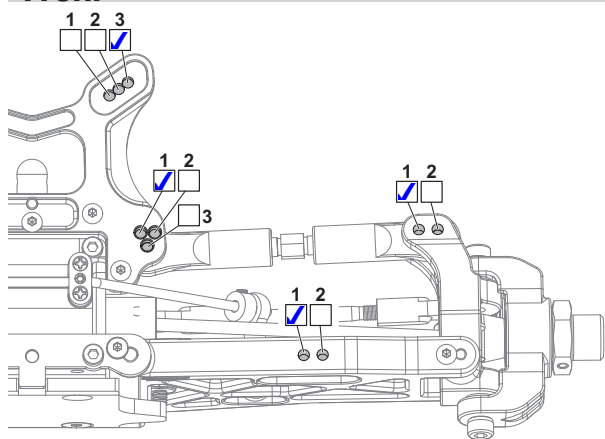

Setup Sheet

Name **Travis Amezcua**Date **Nov 6-8-2009**Event **Sidewinder Nitro Explosion**Temp **Air** TrackTrack **Thunder Alley Rc Raceway**Track Condition **Outdoor** Indoor Tight Open Smooth Rough Hard Packed Loose Loamy Dry Blue Groove Wet Low Bite High Bite Dusty Mealy Other

Front

Ride Height **28** mmCamber Angle **-1** °Toe Angle **1 out** °Sway Bar **2.3** mm

Shocks

Front Rear

Piston **1.3** **1.3**Oil wt. **350** **500**Bladder **Stock** **Stock**Spring **Grey** **White**Shock Length **99.5** mm **100.5** mm

Rear

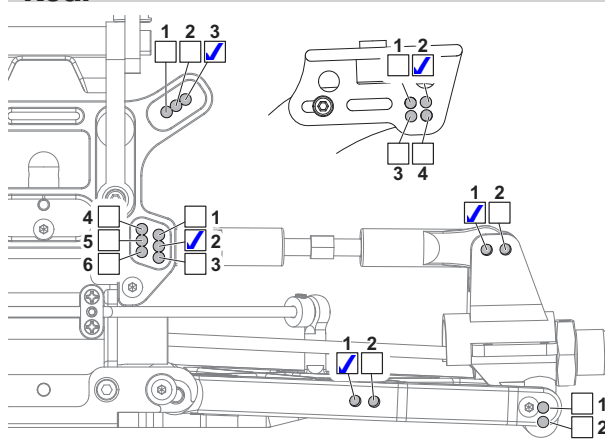
Ride Height **29** mmCamber Angle **-2** °Toe Angle **Stock** °Sway Bar **2.5** mm

Tires

Front Rear

Brand **PL Hoeshots** **PL Hoeshots**Compound **M3** **M3**Insert **Grey Molded** **Grey Molded**Wheel **Pro-Line** **Pro-Line**Notes **Center pin trimmed** **Center pin trimmed**

Chassis

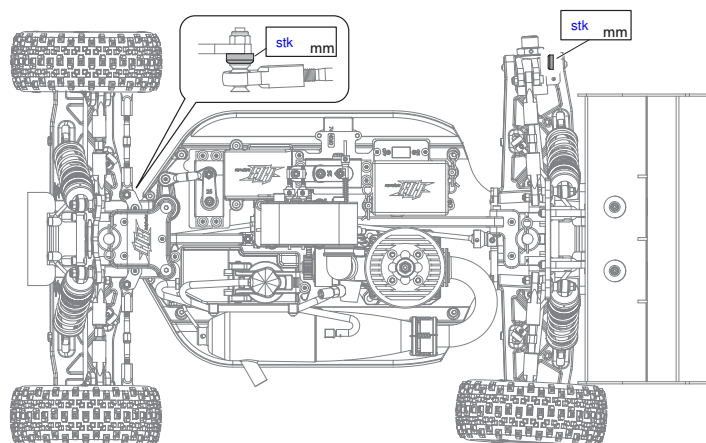
Note **All light weight parts used, 3mm light chassis, Alum spindles and rear hubs.**

Diff

Front Center Rear

Brand **HB** **HB** **HB**Oil wt. **5000** **5000** **2000**

Motor

Engine **Ninja** Spur Gear **Lightened 48**Glow Plug **P3** Pinion Gear **16**Fuel **Sidewinder** Clutch **Stock Trimmed**Pipe **Ninja** Note **2x1.0 and 1x1.1 springs**

HOT BODIES USA
70 Icon Street
Foothill Ranch, CA 92610 USA
(949) 753-1099
(888) 349-4474 Customer Service

HotBodies Distributor in Asia
HPI Japan
3-22-20 Takaoka-kita, Naka-ku,
Hamamatsu, Shizuoka, 433-8119, JAPAN
053-430-0770

HOT BODIES DISTRIBUTOR IN EUROPE
HPI Europe Ltd.
21 William Nadin Way, Swadlincote,
Derbyshire, DE11 0BB, UK
(44) 01283 229400