



Setup Sheet



Name **Travis Amezcua**

Date **10-4-09**

Event **Pro-Line Gas Champs**

Temp **Air 65** Track

Track **Thunder Alley RC Raceway**

Indoor	Tight	Smooth	Hard Packed	Blue Groove	Wet	Low Bite	High Bite
Outdoor	Open	Rough	Loose/Loamy	Dry	Dusty	Med	Other

Front

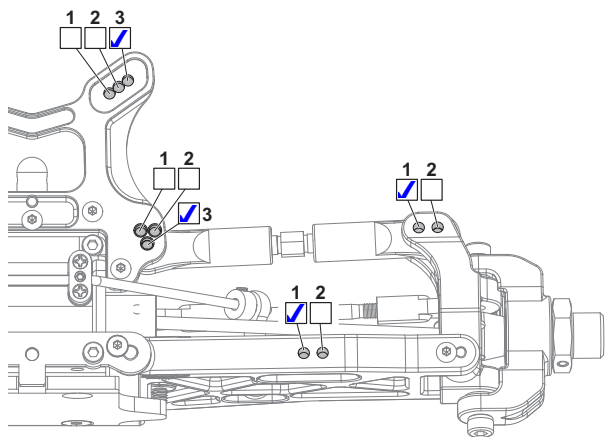

Ride Height **28** mm

Camber Angle **-1** °

Toe Angle **+2** °

Sway Bar **Stock** mm

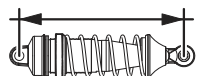

Shocks

	Front	Rear
Piston	1.3	1.2
Oil wt.	500	600
Bladder	Stock	Stock
Spring	White	Yellow
Shock Length	98 mm	101 mm

Rear

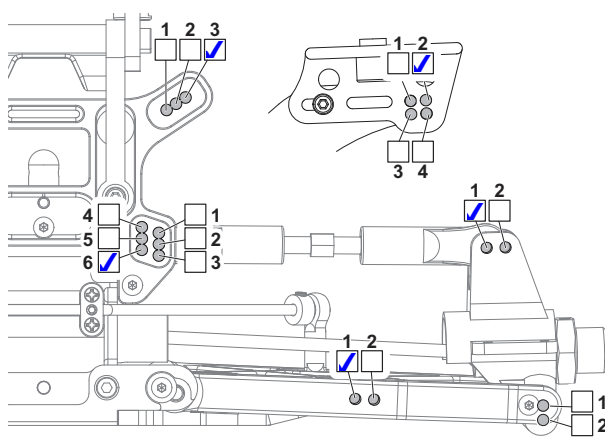

Ride Height **29** mm

Camber Angle **-2** °

Toe Angle **Stock** °

Sway Bar **Stock** mm

Tires

	Front	Rear
Brand	PL Hole Shot	PL Hole Shot
Compound	M3	M3
Insert	Stock	Stock
Wheel	Pro-Line	Pro-Line
Notes	Also used Closed Cell	Also used Closed Cell

Chassis

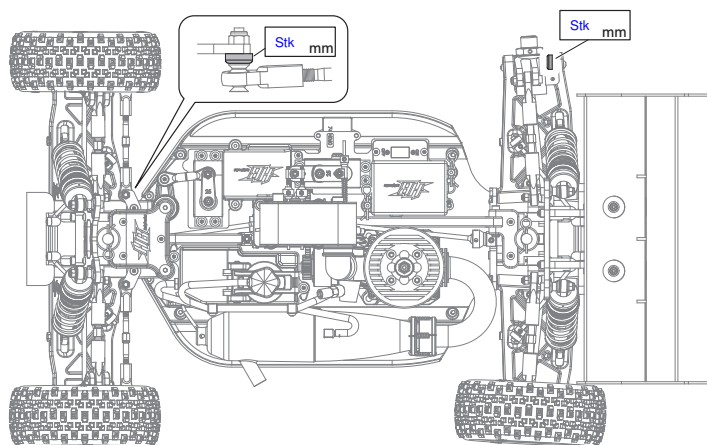

Note **Aluminum Spindles and Rear Hubs**

Diff

	Front	Center	Rear
Brand	HB	HB	HB
Oil wt.	5000	5000	2000

Motor

Engine	Ninja	Spur Gear	48
Glow Plug	P3	Pinion Gear	16
Fuel	Sidewinder	Clutch	Plastic Cut
Pipe	Ninja	Note	2-1.0 and 1- 1.1



HOT BODIES USA
 70 Icon Street
 Foothill Ranch, CA 92610 USA
 (949) 753-1099
 (888) 349-4474 Customer Service

HotBodies Distributor in Asia
HPI Japan
 3-22-20 Takaoka-kita, Naka-ku,
 Hamamatsu, Shizuoka, 433-8119, JAPAN
 053-430-0770

HOT BODIES DISTRIBUTOR IN EUROPE
HPI Europe Ltd.
 21 William Nadin Way, Swadincote,
 Derbyshire, DE11 0BB, UK
 (44) 01283 229400